

SPEC:
A. Material:
 1. Housing: PA66
 2. Terminal: COPPER ALLOY, TIN PLATED
B. Electrical Characteristics:
 1. Rating: 10A 250V~
 2. Electric Strength: AC 2,000 V FOR ONE MINUTE
 3. Insulation Resistance: 100MΩ MIN, AT 500V DC
C. Approvals:
 UL, CUL, CCC, VDE

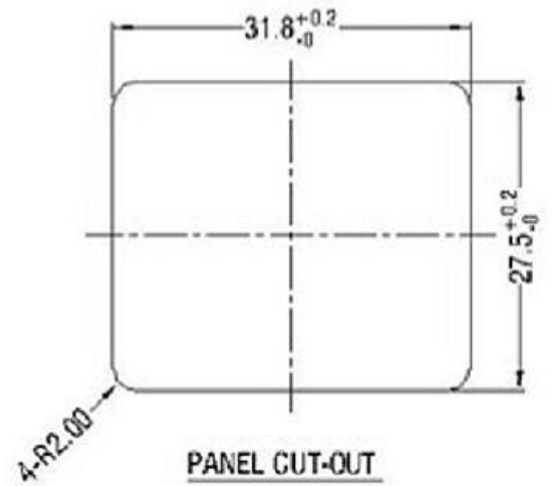
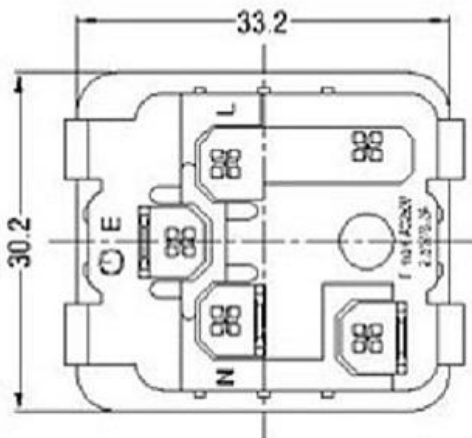
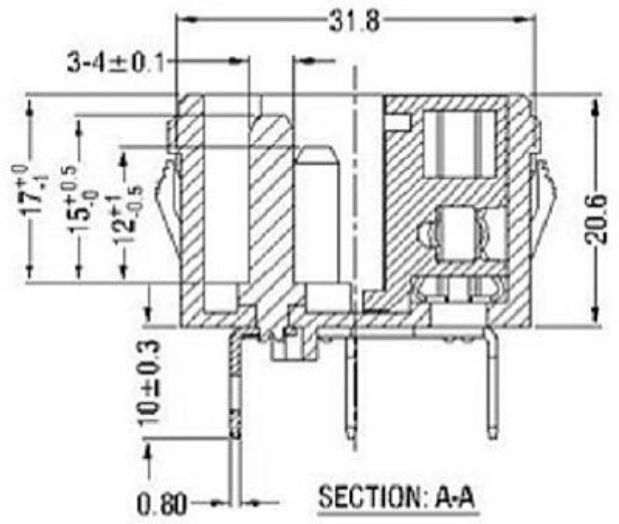

				普通公差 COMMON TOLERANCE :	 东莞市高迪电子有限公司					
				UP TO 5 ±0.20					单位	mm
				ABOVE 5 TO 30 ±0.30	绘图	林晓良	核对应		型号	
				ABOVE 30 ±0.50	日期	19.08.12	核准		料号	KD-AC电源插座
REV.	DATE	REVISION DESCRIPTION	ISSUE	ANGULAR ±5°	DATE		APPROVAL BY		PART NO.	